

Carlson's SuperProbe PCB Kit Assembly

MK1 Kit with 26 Parts

MK2 Improved with 35 Parts

This is an advanced SMD skill PCB build. Please take your time!

First, thanks for purchasing this kit. These instructions are for our first kit with 26 parts and our improved kit with 35 unique components included. There are many implementations of this non-contact probe on the web, but most seem to have stuck to Paul Carlson's design rather closely. Since neither kit includes the cases, probe tip, battery or speaker needed to arrive at a final working probe. You can't go wrong reviewing and following the implementations presented on the Instructables website. In particular, this kit is based on the PCB designs from Yannick99. Certainly you should watch Carlson's original YouTube video on the probe. I can't do better in describing its adjustment and use.

Original MK1 Kit

The original kit provides all of the parts for the 2 PCBs, the 2 pots & lamp. Everything else must be builder sourced.

New MK2 Kit Version

The new version of the Super Probe kit contains essentially all of the parts for both the Amp and Probe except the *cases, battery & holder, probe tip & speaker*. It includes everything for the PCBs, knobs for control POTS, probe shielded connection cable, probe plug & jack, power switch and LED, #22GA Teflon inter-connect wire & shrink tube. The Probe PCB is revised with mounting holes and grounded pads on the top (silk) side of the board.

Assembly

The PCB parts are almost exclusively SMD 0805/1206 size components, and will require a skill level and tool set commensurate with these parts. Some form of microscope is also highly desirable for assembly and inspection. The amplifier PCB has modified mounting holes to match the mounting boss in Hammond plastic boxes using #4-40 button cap screws. But you can just as easily use hot glue! The new probe PCB has 3 #0-80 mounting holes located in ground pads, but you will have to use your own creativity to fashion the complete probe. The 2 pads on top next to the probe tip input are now grounded to the back-plane. Use these for reinforcing the tip support or mounting the PCB. At the output end there is now a ground pad on the top.

There are 34 different components shared between the two PCBs, each in its own plastic bag (including wire & shrink tube). They are each numbered and labeled to match the parts list. I recommend sorting the poly bags by number so you don't lose track of any. For a sane and successful assembly, **DO NOT OPEN MORE THAN ONE BAG AT A TIME!** I don't think that there is a good or bad sequence to the assembly, and you do not need to follow the bag numbering. But you had best attach all of one type of component to both PCBs before opening another bag, and check off the parts on the part list as you go. (For most components, there are 1-2 extras, but not for the expensive parts!)

Use a good quality clean or no-clean liquid or gel flux. But clean your assembly with soap & water or acetone (as appropriate for the flux used). Use caution in washing the probe PCB switch & pot. I recommend mounting these thru-hole components last.

Only 3 components are polarized (5 - 22uF caps, 1 - Schottky diode & 1 - LED). Unfortunately the original drawings don't easily show this, so look closely at the pictures and schematics where I have added "+" marks. In particular, note that the schottky diode banded end should point **toward** BJT T5s base pin and C9. It is easy to get this wrong, as I did twice.

R16 (10K) in the output EF (T6) of the probe PCB is not normally installed. But if you choose to test or use the probe PCB as a stand-alone circuit you will need this to bias the emitter follower. Then you can drive any audio amplifier through its input filtering network.

The amplifier speaker is NOT grounded, so take care that you never let a speaker lead touch the common or it may permanently damage the LM4871 chip.

Testing

Because this kit is only part of the complete SuperProbe, there are many ways of testing each PCB. Check the power rail for shorts or very low resistance. Check for bridged solder joints. Use a current limited supply or series resistance and measure power supply current. The probe PCB draws only hundreds of micro amps, while the amp PCB noticeably more with the speaker attached. If you have problems with the SuperAmp, check your power supply connections and contacts. This LM4871 requires 100-200 mA to power up, where it then idles at 10-20mA. A poor power supply will cause motor-boating where the amp repeatedly powers up and down. The SuperAmp schematic shows the expected DC node voltages with VCC=4.5V.

Case & Housing Options

Almost anything can be used to house the amplifier, and we have included a quality 3.5mm stereo jack & plug. The amplifier can be powered using 3.5-5.5VDC from a variety of sources. But 4-AA batteries are the limit for the integrated power IC in the amplifier. Do stick with some form of 4 ohm 2 watt speaker, as reviewers complain about performance with other speakers.

The probe case **must** be all metal and connected to the common of the probe PCB (bottom), shield of the wire probe tip and shield & common of cable to the amplifier. A bare metal probe case can be a hazard around high-voltage circuits. Use insulation and safety techniques any time the voltage is greater than 48VDC. And even then, remember that a 10A 48V supply can do some real damage if a ring on the finger is used to test continuity!

You can use just about anything for the actual probe tip wire. I had some 1/8" rigid copper coax. Others have used 1/8" flex coax. Just insure that only about 1/16" of the tip of the wire has the shield removed.

Compromises

Carlson designed this probe to be as simple as possible yet have flexibility. Because the probe operates from a variable power supply, both amplifier controls affect the probe sensitivity. But because the probe consumes so little power, the voltage regulator pot was set a 2K. There is a risk in testing or use that the probe power lead may be shorted to common accidentally. This WILL destroy the pot. To protect against this, I have included a 6V-40mA lamp that can be placed in series with the voltage regulator pot wiper lead (as Carlson did). Normally it is just 10s of ohms. But short the power lead and it will glow to protect the pot wiper. Fit it anywhere that makes sense. *(There remains the possibility, with a stereo type jack, of shorting the power momentarily if the probe is plugged or unplugged with the power switch on. The lamp will protect against damage in this case.)*

I do not find the LED pop indicator to be very useful. It may be my choice of a LED. The LED is biased through 1K ohm to the probe supply. Since this supply has a rather high output resistance (the pot), the LED can't be made really bright. Yes it can be made to flicker, but you have to be looking at it. So physical positioning of the LED should be considered early in the probe case design.

Part List

The following list indicates all of the parts included in the kit. While I stuck to the parts specified by Yannick99 where I could, some were not available or were unreasonably expensive. The GREEN backgrounds are the kit part numbers. I have also indicated both the required component count and the included kit component count.

SuperProbe Kit MK1(26) or MK2(35)			4/24/24	V3.1				
bag line #	desc	part #	alt part #	qty-req	qty-kit	val	size	pol
MK1 Kit								
1	C	CL21B103KBANNNC		3	5	0.01uF	0805	none
2	C	TAJA226K010TNJ		5	6	22uF	1206	+band
3	C	CL21B104KBCNNNC		3	5	0.1uF	0805	none
4	C	CL21A475KOFNNNE		4	5	4.7uF	0805	none
5	C	80-C0805C361J5G		1	2	360pF	0805	none
6	C	CL21B105KAFNNNE		1	2	1uF	0805	none
7	D	1N5711WS	1PS76SB70,115	1	2	1N5711	SMD	K band
8	Q	MMBT3904		7	9	2N3904	SMD	
9	R	ERJ-6GEYJ335V		5	7	3.3M	0805	
10	R		CRGCQ0805F15K	3	5	15K	0805	
11	R		CRGCQ0805F2K7	1	2	2.7K	0805	

12	R		CRGCQ0805F1K0	5	7	1K	0805	
13	R		CRGCQ0805F330K	1	2	330K	0805	
14	R		CRGCQ0805F10K	1	2	10K	0805	
15	R		CRGCQ0805F22K	3	5	22K	0805	
16	R	ERJ-6ENF6802V	CRGCQ0805F68K	1	2	68K	0805	
17	R		CRGCQ0805F100R	1	2	100	0805	
18	VR	CT-6EX104		1	1	100K	TH	
19	VR	eBay	P160KNP-0EC15B2K	1	1	2K	PNL	LIN
20	VR	987-1736	P160KNPD-4QA15A5K	1	1	4.7K	PNL	AUD
21	SW1	EG2350	OS102011MA1QN1	1	1	SPDT	TH-RA	
22	U	LM4871MX/NOPB		1	1	LM4871	SMD	
23	PCB			1	1	SupAmp		
24	PCB			1	1	SupProbe		
25	LED	SSL-LX3054SRD	noise	1	1	320mcd	T1-red	320mcd
26	LMP	560-1730	CM683	1	1	6V-40mA		
Plus MK2 Kit								
27	Knob	Amazon	1106WA	2	2	6mm	knurled	
28	jack	Amazon	161-7400-EX	1	1	3.5mm	stereo	
29	plug	Amazon	17PP004-EX	1	1	3.5mm	stereo	
30	SW2	Amazon	200MSP6T1B1M2REH	1	1	toggle		
31	CBL	Mouser		4	4	ft	stereo	shielded
32	WRE	#22 teflon		4	4	ft	#22	wire
33	R		470	1	1	470	axial	LED
34	HST	1/8" shrink tube		1	1	ft		
35	LED	WP710A10SED	power	1	1	1100mcd	T1-Org	1100mcd

SuperAmp Part List

MCSAmp 4/24/24				
Kit	Item	Quantity	Reference	Part
MK1	1	1	C1	1uF
MK1	2	2	C2,C6	22uF
MK1	3	1	C3	0.1uF
MK1	4	2	C4,C5	4.7uF
MK1	5	1	T1	2N3904
MK1	6	3	R1,R2,R5	22K
MK1	7	1	R4	68K
MK1	8	1	R6	100
MK1	9	1	R7	2K
MK1	10	1	R8	4.7K
MK1	11	1	R3	1K
MK1	12	1	U2	LM4871
MK1	13	1	DS1	6V-40mA
MK2	14	1	J1	3.5mm jack
MK2	15	1	D1	Org LED
MK2	16	1	R9	430-470

MK2	17	2	KB	6mm Knurl Nobs
MK2	18	1	SW1	Pwr SW
MK2	19	24"	#22	Hook up wire
MK2	20	12"	1/8"	Shrink tube

SuperProbe Part List

MCSP Revised: 8/31/23				
Kit	Item	Quantity	Reference	Part
MK1	1	3	C1,C3,C10	0.01uF
MK1	2	3	C2,C5,C7	22uF
MK1	3	2	C4,C6	0.1uF
MK1	4	2	C8,C11	4.7uF
MK1	5	1	C9	360pF
MK1	6	1	D1	POP-LED
MK1	7	1	D2	1N5711
MK1	8	6	T1,T2,T3,T4,T5,T6	2N3904
MK1	9	5	R1,R4,R7,R9,R15	3.3MEG
MK1	10	3	R3,R6,R11	15K
MK1	11	1	R8	2.7K
MK1	12	4	R2,R5,R10,R14	1K
MK1	13	1	R12	330K
MK1	14	1	R13 (POT)	100K
MK1	15	1	R16	10K
MK1	16	1	SW1	SPDT
MK2	17	1	JP1	3.5mm plug
MK2	18	36"	3w+sh cable	cable

Feedback

It takes quite a bit of effort to put kits like this together, and it is easy to make a mistake or omission. If you find errors, omissions, or if you have suggestions on the instructions, kit, packaging or anything else, I would be happy to receive feedback.

- Is the cable long enough?
- Are there enough extra SMD parts?
- Are the instructions adequate?
- Do you have tweaking feedback for us?

I would encourage you to add your implementation to the Instructables "I Made This" section!
The easiest way to provide feedback would be by email to:

Kevin
hcsales@hwcz.com or ppsales@hwcz.com

References

<https://www.youtube.com/watch?v=uVkJqqZroN0&t=2583s>
<https://www.instructables.com/Carlsons-Super-Probe/>
<https://www.hollywoodcontrols.com/phpSP/MCSP.php>

Super Probe MK2 PCB Kit Parts

Super Probe MK1 PCB Kit Parts

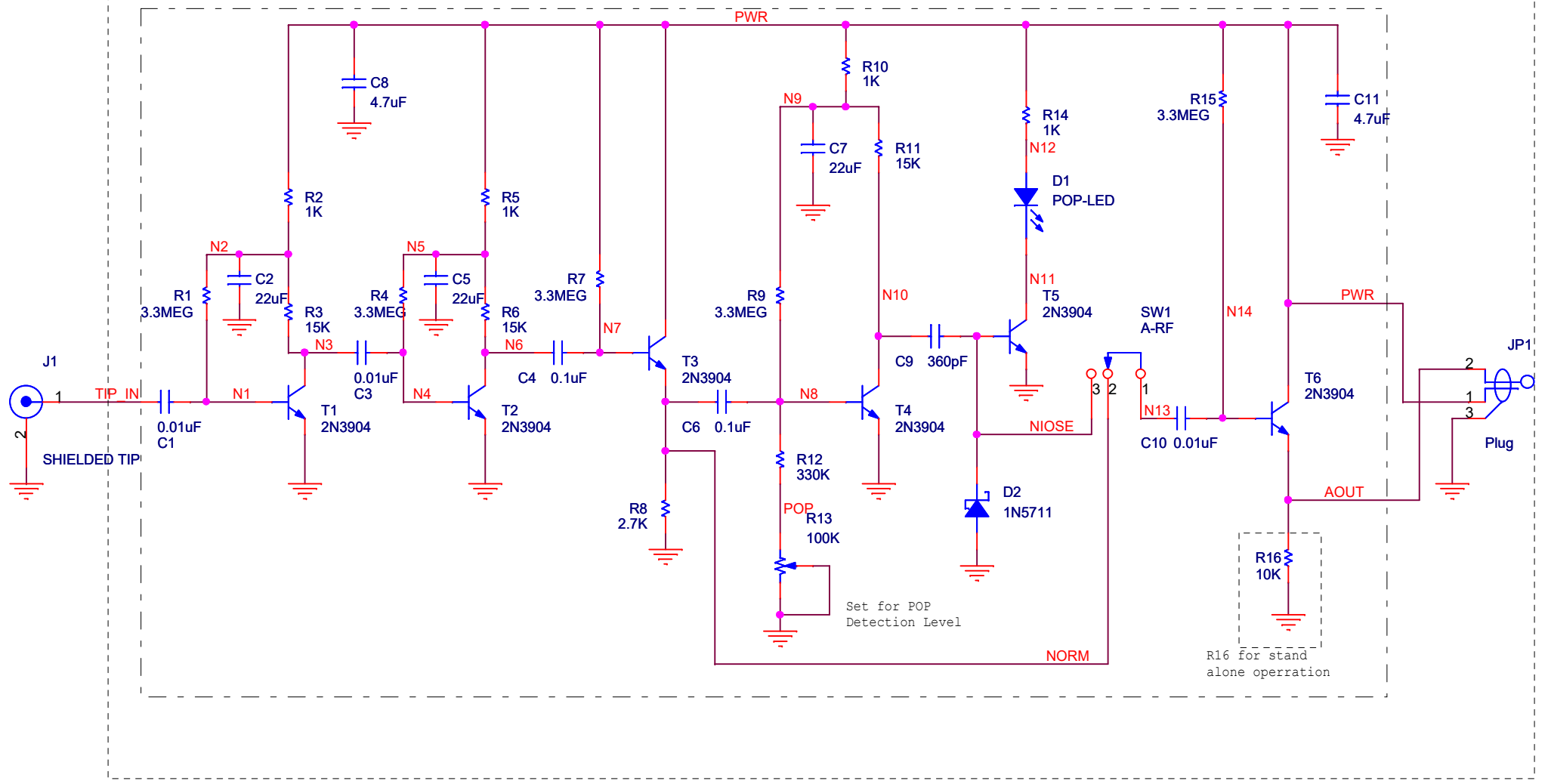

Set for POP
Detection Level

R16 for stand
alone operation

Title		
Mr Carlson's Super Probe		
Size	Document Number	Rev
A	<Doc>	v3.0
Date:	Thursday, August 31, 2023	Sheet 1 of 1

Node Voltages Vbatt = 4.5
 BATT 4.5
 A2 0.91
 A3 0.23
 A4 2.18
 A6 2.25
 A7 2.25
 A8 2.24
 A9 2.24

USBC1

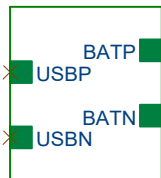

TP4056

Super Amp MK2 PCB Kit Parts

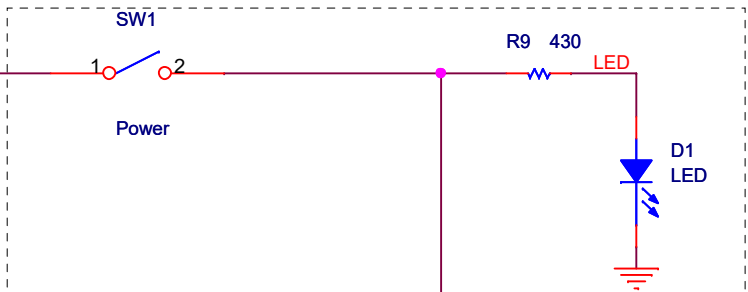

Optional Overload Lamp

Super Amp MK1 PCB Kit Parts

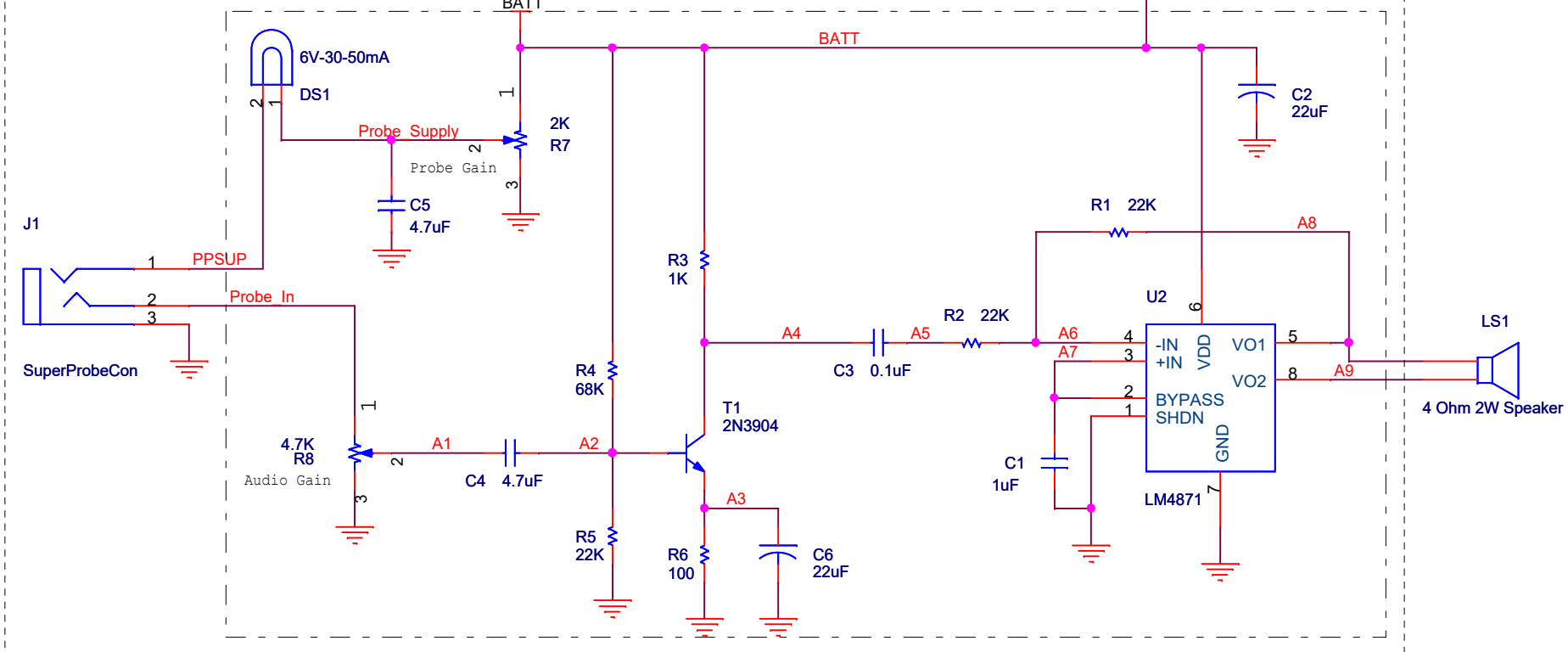

Title		
Mr Carlson's Super Amp & Li-Ion Power		
Size	Document Number	Rev
A	<Doc>	3.0
Date:	Thursday, August 31, 2023	Sheet 1 of 1

Drawing V2

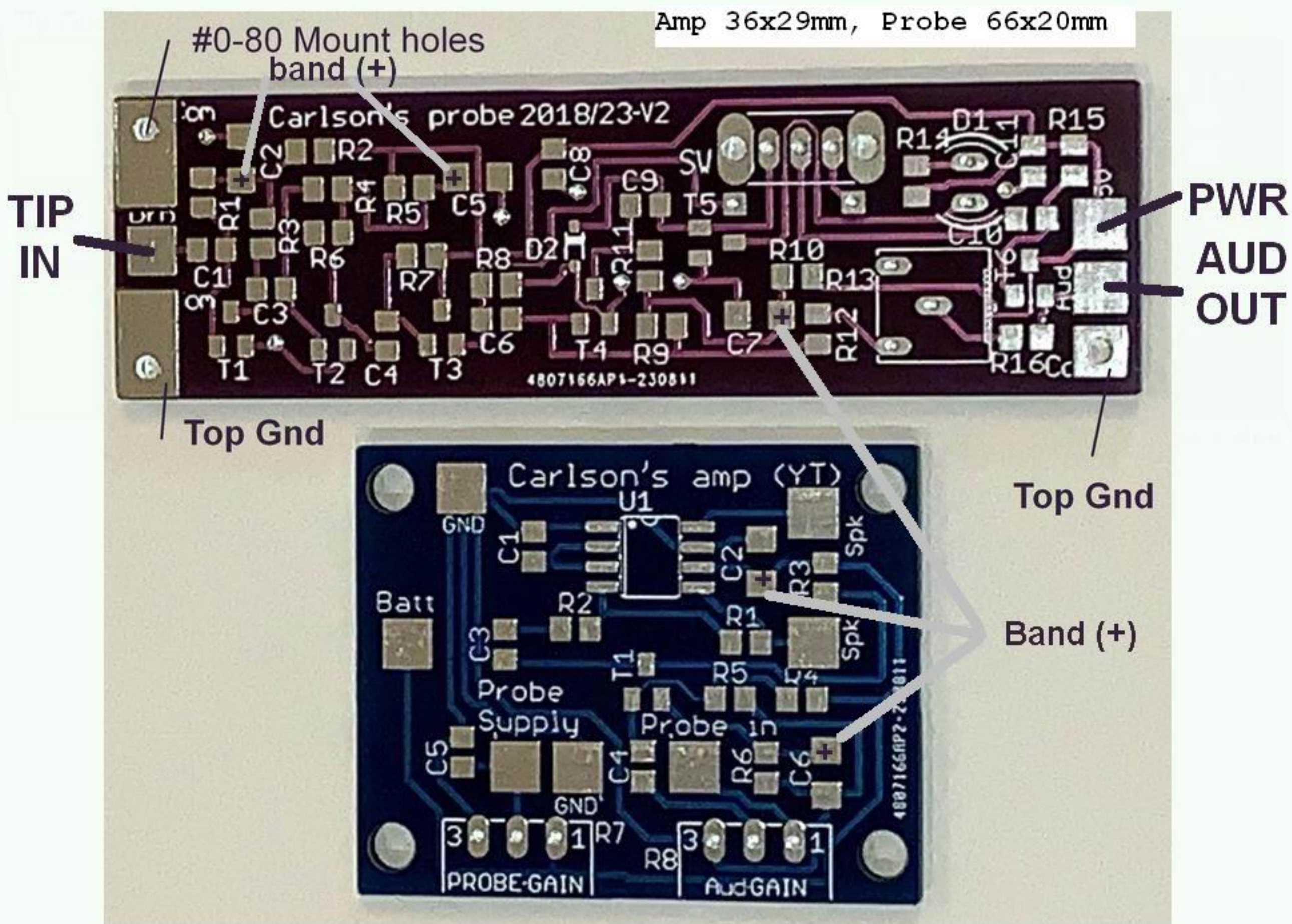
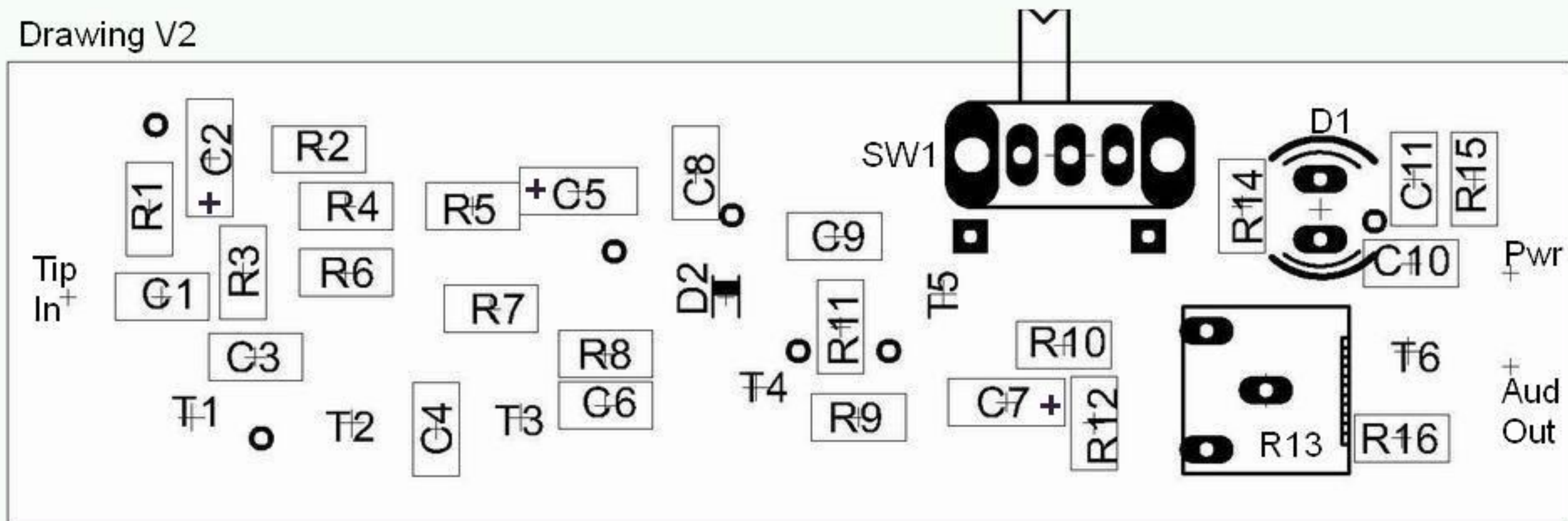

Pos +

Band UP

anode

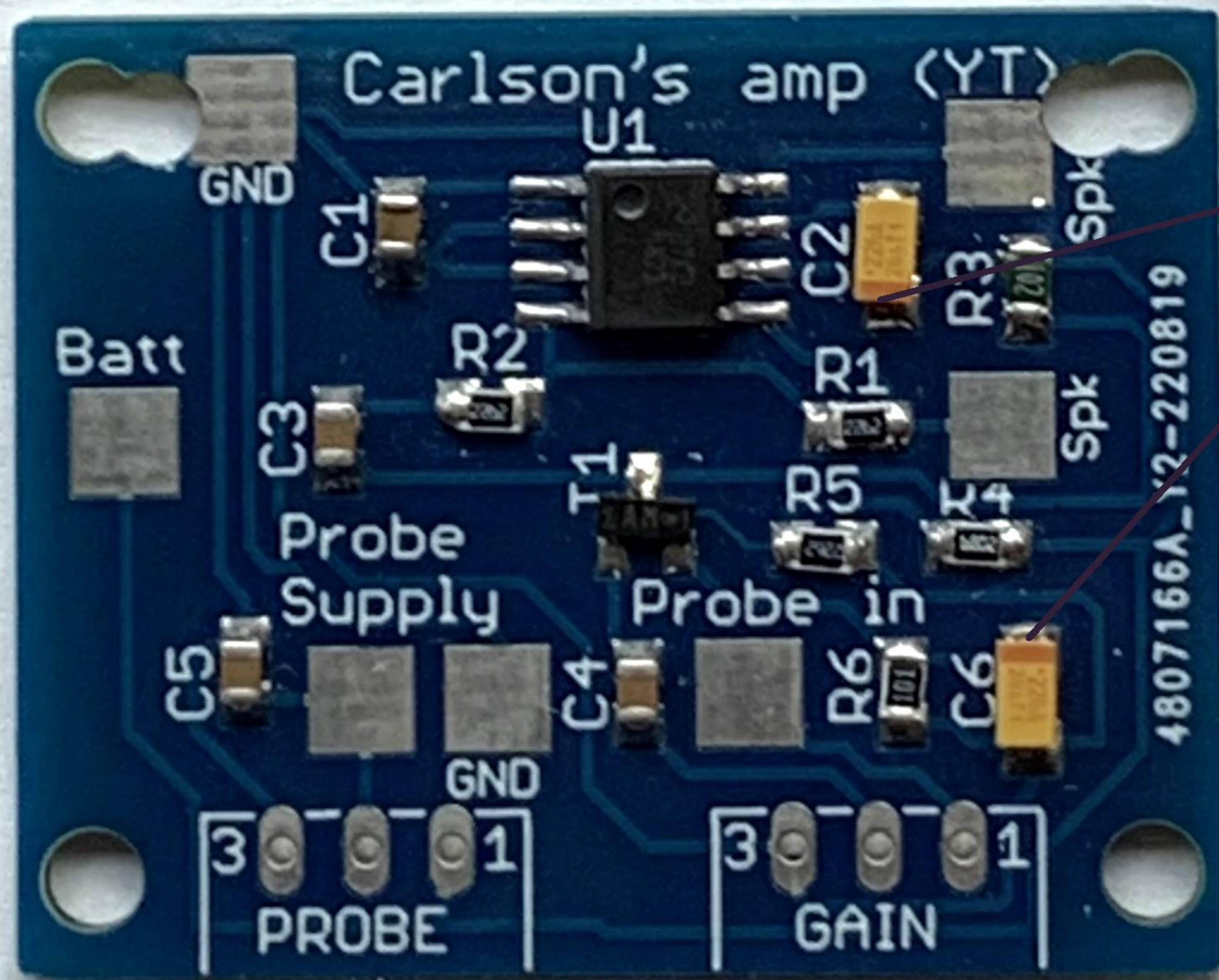
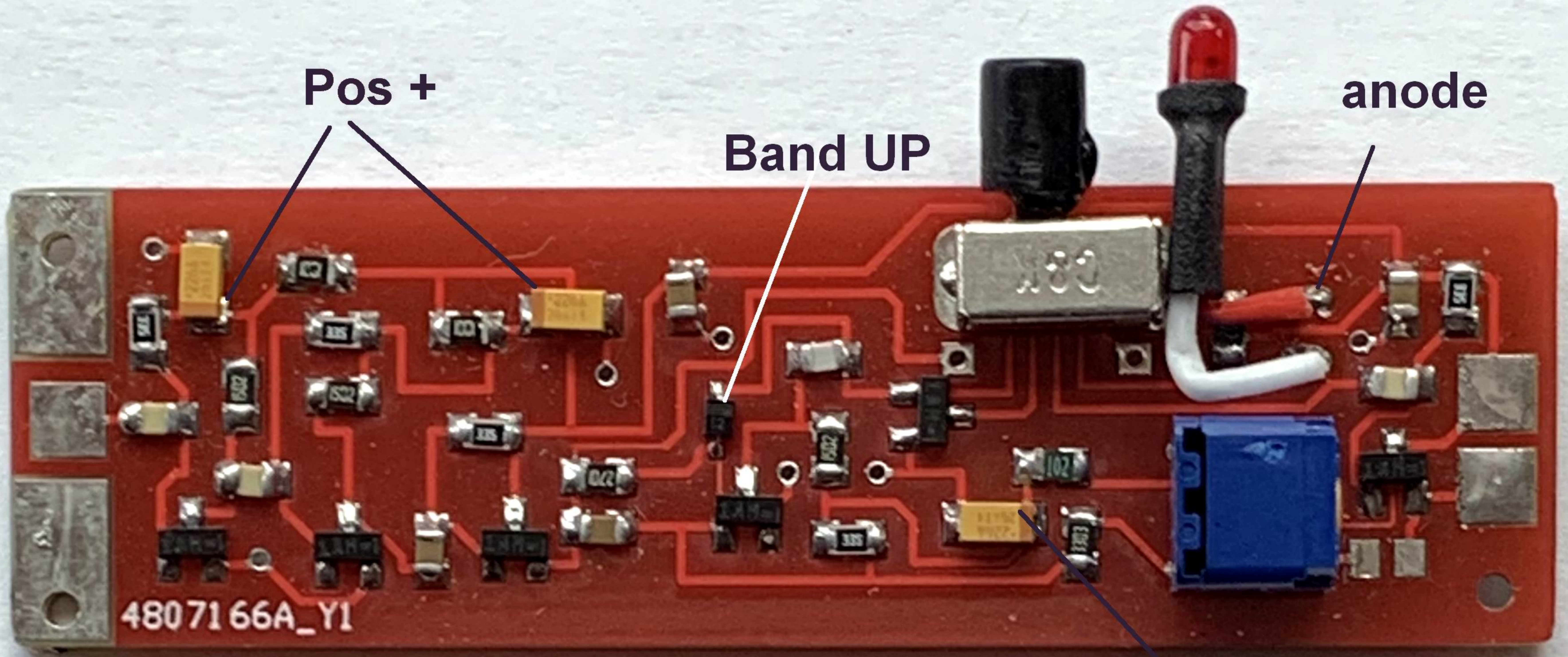

Pos +

